

NEEDLE DETECTOR

The latest needle detector from YDS Ltd truly represents the 3rd generation of metal detectors designed to satisfy all the application and functional requirements in clothing and footwear factories



✧ **High sensitivity with:**

- **High immunity to magnetic disturbances**
- **Immunity to voltage fluctuations on power lines**
- **Unmatched tolerance to non-ferrous accessories**

FEATURES:

- Easily meets the sensitivity demands of all leading retailers
- High immunity to magnetic disturbances from sewing machines
- Detector completely unaffected by electrical supply voltage fluctuations (from 86 – 260 volts)
- Quick-release conveyor system for easy cleaning and belt change without tools
- Polished stainless steel conveyor frame for strength and lifetime appearance
- Product memory function
- Secure operation prompts supervisor intervention when a contaminant is found
- All parameters and detector settings are pass code protected

DIGITAL DISPLAY:

State-of-the-art high-speed 32bit RISC processor based architecture ensures:

- New, fast and accurate detection algorithms
- Large product and event memory
- Multiple communications options
- Field and remote upgradeable firmware capability



OPTIONS AVAILABLE:

- PC connectivity for comprehensive production reporting and due-diligence audit trail

**OTHER SIZES AVAILABLE ON REQUEST
DEPENDANT ON APPLICATION**

SPECIFICATIONS:

Model	225	228	229
Detection method	Balanced coil	Balanced coil	Balanced coil
Sensitivity	1.0mm ferrous metal sphere	1.2mm ferrous metal sphere	1.5mm ferrous metal sphere
Detection height	125mm	200mm	225mm
Detection width	550mm	550mm	550mm
Alarm method	Buzzer, Belt stop	Buzzer, Belt stop	Buzzer, Belt stop
Belt speed	30 m/min	30 m/min	30 m/min
Power supply	220 V / 1 phase	220 V / 1 phase	220 V / 1 phase
Power consumption	400 VA	400 VA	400 VA
Machine dimension (mm)	L 2000 x W 1000 x H 1010	L 2000 x W 1000 x H 1160	L 2000 x W 1000 x H 1260
Machine weight	350 kg	375 kg	385 kg
PC interface	RS 232 output / USB Connectivity	RS 232 output / USB Connectivity	RS 232 output / USB Connectivity

Overall dimensions in millimeters Model 225:

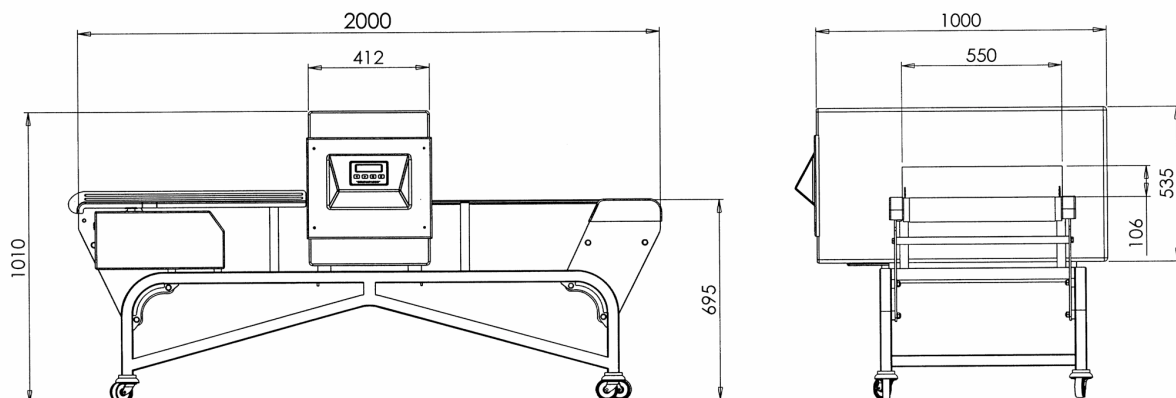

As part of a continuing process of development, YDS Limited reserves the right to alter specifications and other product details without notice

© Copyright 2001-2006 York Detection Systems Limited

YDS York Detection Systems Ltd
Tel: +44 161 622 3600 Fax: +44 161 678 7688
Email: sales@yorkdetection.com

Distributed By: